

DISD

SD 300 / SD 200



Exceeding Expectations while Bearing High-load

SD300 / SD200 has set out to perfectly integrate world class technologies with a new low-speed engine creating a higher level of efficiency to save fuel while maintaining a level of power that will more than your expectations.



Features Overview

- Stronger breakout force and tractive force, reflecting excellent performance in a high-load working environment.
- Ideal operating speed and 40° steering angle, sharply improving work efficiency.
- Low-speed engine, saving more fuel for the device.
- Reasonable matched top-end technology, ensuring a more reliable, durable and efficient device.
- Noise reduction technology in line with international standards, providing operator with physical and mental protection, while bolstering work efficiency.
- Industry leading cooling system, offering a guarantee for continuous and uninterrupted work under high temperatures.
- Streamlined appearance and wide operating room, representing an international brand style.

SD 300 / SD 200

Powerful Wheel Loader

High Efficiency and Super-Operating Performances

Combined Loop

Reducing oil consumption and improving cooling performance.

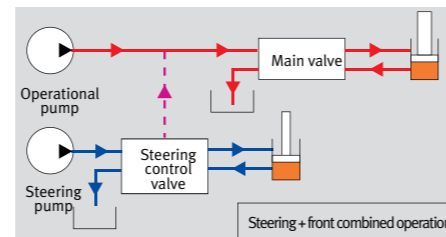

SD300 Only

Diesel Engine for Loader

Fuel saving and environment friendly low-speed engine, satisfying Tier-II emission standards.



Performance

SD300 / SD200 features powerful performance under poor working conditions with high efficiency and fuel saving operation.



- 1 Fast Operating Speed**
Significantly improved work progress, reduced work time, and reached excellent perfectly balanced for optimal work efficiency.
- 2 Strong Breakout Force**
Released through the best combination of hydraulic systems, under any working conditions, to create outstanding results.
- 3 Centralized and Combined Switch**
A button placed at the lower right of steering wheel, making it easy and convenient to control the operations of the electrical components on the loader.



Rearward Visual Field broadened by 20%
 The rear end of the device adopts streamline design which largely broadens the rearward visual field of the operator, improving not only the work efficiency but also safety.

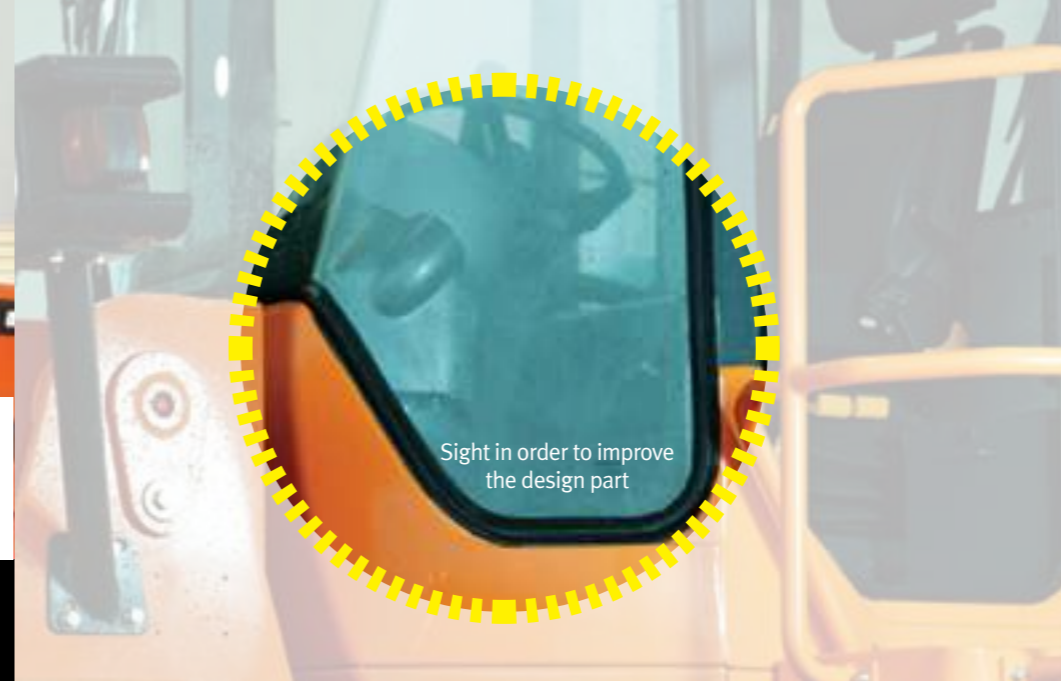

Sight in order to improve the design part

Cabin with Ergonomic Design

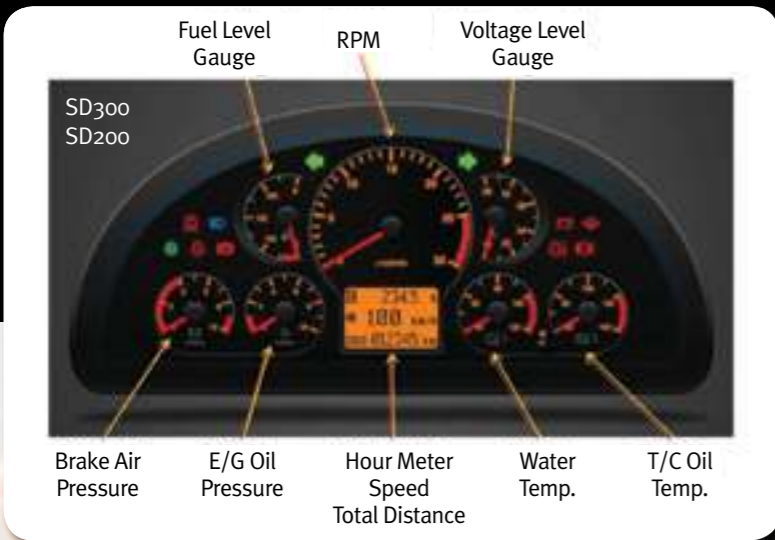

New Operator Panel
 The instrument panel has been changed to improve operator comfort and convenience.

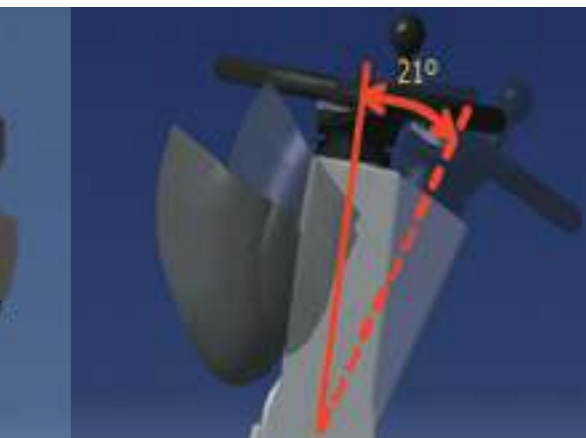
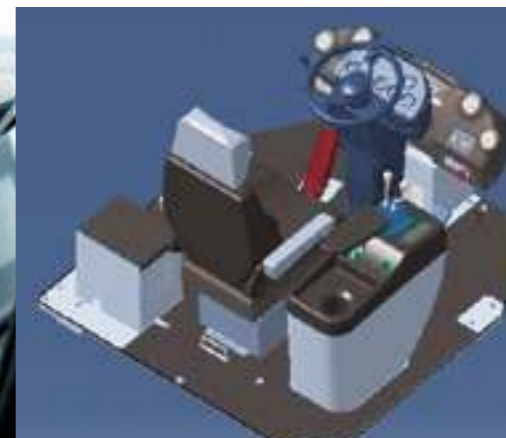

Cabin

- Enough space.
- Wide visual field.
- Noise inside cabin is lower than comparative units.
- Comfortable operating space.
- Multi-angle adjustable steering wheel.

Universal Cabin Features
 Human oriented design

- High grade appearance of international standards.
- Wide operating space with low noise.

Adjustable Steering Wheel
 Complying with ergonomic principles

- Backward: 21°

Air Flow Increased by 30%
 Excellent air-conditioning system and air circulation function as well as perfect defrost system provide operator a more comfortable operating environment and more easy controlling methods to benefit from the above functions.



Lower Noise
 Offering a quiet and comfortable working environment and improving efficiency.

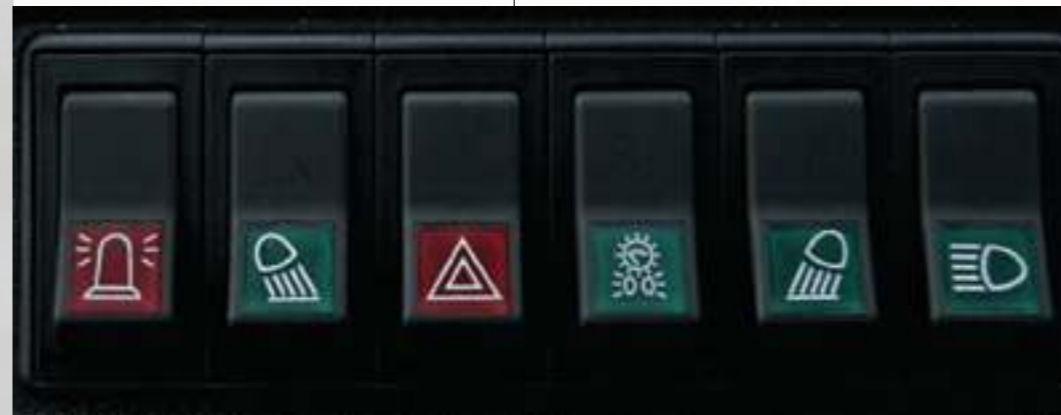
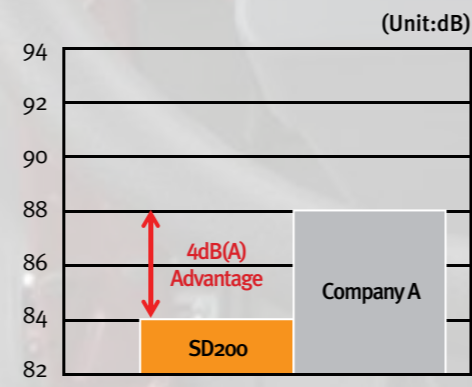
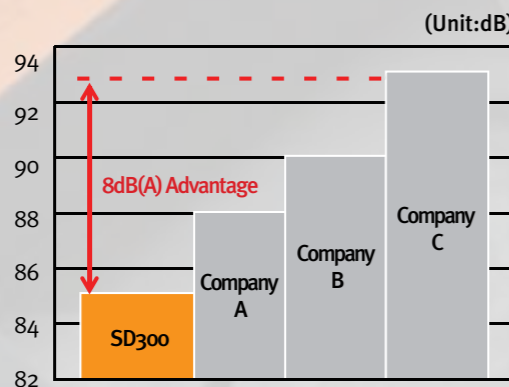

Preheat
 A starter designed for the actuation at low temperature in winter with mighty battery capacity, resolves starting difficulties at low temperature with one key.

Easy Controlled Rocker Switches
 All the switches are arranged in concentrated and combined ways, easy to operate, and complying with ergonomic principles.

High-quality Sound System
 Relieving long time operating fatigue, equipped with USB port which can be connected with MP3 music player or mobile phone charging device.

SD 300 / SD 200

Powerful Wheel Loader

Solid and Durable, Extending Service Life,
Saving Device Replacement Cost

Solid Frame Structure

The most advanced 3D CAD and FEM technologies are adopted in the analysis of technical design, greatly improving the strength, durability and reliability of the device.

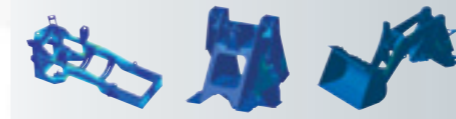

Reliability

The highly reliable components and anti-abrasive material not only improved the durability of the device, but also enhanced its work efficiency and extended its service life.



Reinforced Radiator Grill Molding

The rear radiator grill molding with steel bar structure is solid and can prevent damages from the outside.



Transmission Shaft : Double Bearing Drive Shaft (SD300)

- Double bearing supporting propeller shaft in dual configuration for improving reliability of propeller shaft.
- Lubricating oil can be infused easily, enhancing the durability of the transmission shaft.



Cooling Performance

An optimal radiator design ensures the good performance of the loader and enhances the durability of parts such as the engine and pumps etc.

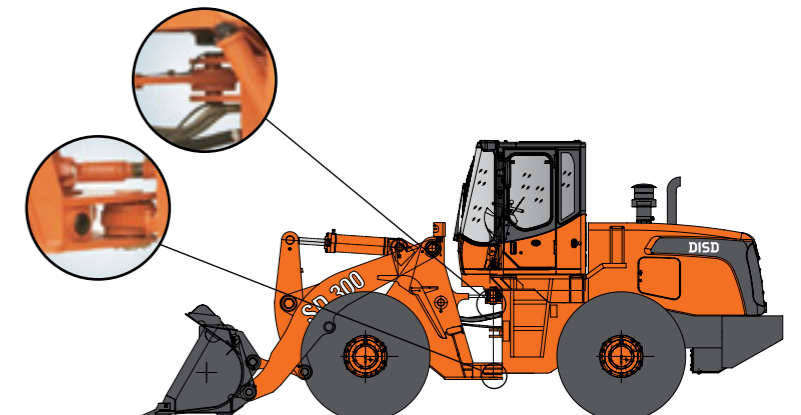

Durability

SD300 / SD200's working attachments and articulated pin are matched properly in size so as to position the force bearing area accordingly, increase diameters of the boom pin roll and front and back frame articulated pin roll, as well as enhance durability.

SD 300 / SD 200

Powerful Wheel Loader

Convenient Top-end Maintenance Management System

Open-end Hood

The hood can be opened completely not only to refill oil/gas and replace inner parts but also for the daily maintenance of the engine its adjacent devices.



Maintenance

The replacement cycle of vulnerable parts are substantially extended. Spacious maintenance space makes the maintenance work done more quickly and conveniently.



High Efficiency Cooling Fan

The cooling fan of 7 non-isometric blades can reduce noise and increase air flow.

Quickly Changeable Brake Disc

Brake disc can be replaced quickly and easily without disassembling tires, deeply shortening the maintenance time and saving time and labor cost.

Full Tilting of Engine Cover

With this one body engine cover, it is easy to repair engine and sub parts.



Easy and Quick Adjustable Maintenance Window

The 180°side-opened maintenance window provides a quick and direct view for inspection, largely saving daily monitoring and maintenance time.



Inspection for High/Low Hydraulic Oil Level

Used to monitor the hydraulic oil level more easily to reduce maintenance time, improving device service lifetime.



Outdoor Power switch

Used to cut off battery power when necessary to enhance maintenance safety and convenience while protecting the battery and extending battery life when the device is parked for a long time.

Technical specifications SD300

SD 300

ENGINE

MAKER & MODEL : Wei chai WD10G220E23
(TIER-II Certified)
RATED HORSE POWER : 162 Kw/2000 rpm
MAX. TORQUE : 930 N.m
FUEL CONSUMPTION : 225 g/kw.h @ RATED SPEED
TYPE : TURBO,DIRECT INJECTION

DISPLACEMENT : 9726 cc
NO. OF CYLINDER : 6
BORE & STROKE : 126 X 130 (mm)
HIGH IDLE SPEED : 2160~2240 rpm
LOW IDLE SPEED : 750 rpm
STARTING MOTOR : 24V X 7.5 kw

ALTERNATOR :

VOLTAGE : 28 V
RATING AMPERES : 55 A

FAN :

TYPE : BLOWING , 7 BLADE, STEEL
SIZE : Ø760 mm
RPM @ MAX ENGINE RPM : 2000 rpm

BATTERY :

SYSTEM VOLTAGE : 24 V
QUANTITY : 12 V x 2
CAPACITY : 120 AH

RADIATOR :

TYPE (HEAT REJECTION AREA) : FLAT PLATE FIN,
AIR COOL(=59.1 m²)
HEAT REJECTION CAPACITY : 200,000 kcal /hr

AIR CLEANER :

TYPE : DRY, DOUBLE ELEMENT
FILTRATION AREA : 11.21 m² (MAIN),
1.49 m² (STEER)
SIZE (DIA. X LENGTH) : Ø290 mm X 450 mm

TRANSMISSION OIL COOLER :

TYPE (HEAT REJECTION AREA) : PLATE, AIR
COOL (=23 m²)
HEAT REJECTION CAPACITY : 75,000 kcal/hr

MUFFLER :

DESCRIPTION : SIDE INLET, VERTICAL TAIL PIPE
SIZE : Ø250 mm X 490 mm

HYDRAULIC OIL COOLER :

TYPE (HEAT REJECTION AREA) : PLATE, AIR
COOL (=13.2 m²)
HEAT REJECTION CAPACITY : 37,200 kcal/hr

TRANSMISSION

TYPE : 2 SPEED, POWER-SHIFT,
PLANET,ENGINE REMOTE
MOUNTED WITH PROPELLER SHAFT & DAMPER
TORQUE CONVERTER STALL RATIO : 4.3
TORQUE CONVERTER SIZE : 315mm
CHARGING PUMP FLOW : 120 l/min at 2000 rpm
HYDRAULIC PUMP P.T.O RATIO : 0.8667/1.022

POWER SHIFT CONTROL PRESSURE : 12~14 kgf/cm²
CONVERTER SAFETY RELIEF PRESSURE : 11 kgf/cm²
MAX. ROTATING SPEED : 2350 rpm
SHIFT CONTROL : MECHANICAL TYPE
OUTPUT FLANGE : FRONT - 9C MECHANICS
REAR - 7C MECHANICS

AXLES

FRONT AXLE :

TYPE : FULLY FLOATING PLANETARY-TYPE HUB DRIVE
FIXED MOUNTING
OVERALL REDUCTION RATIO : 22.853
AXLE LOAD (EMPTY CONDITION) : 8,500 kg
AXLE LOAD (BREAKOUT CONDITION) : 27,000 kg
WHEEL BOLT P.C.D : Ø475 mm
BRAKE TYPE : DRY DISC
BRAKE TORQUE per WHEEL : 13050 N.m at 140 bar
DRIVE FLANGE : 9C

REAR AXLE :

TYPE : FULLY FLOATING PLANETARY-TYPE HUB DRIVE
TRUNNION MOUNTING
OVERALL REDUCTION RATIO : 22.853
AXLE LOAD (EMPTY CONDITION) : 8,500 kg
AXLE LOAD (BREAKOUT CONDITION) : 27,000 kg
WHEEL BOLT P.C.D : Ø475 mm
BRAKE TYPE : DRY DISC
BRAKE TORQUE per WHEEL : 13050 N.m at 140 bar
DRIVE FLANGE : 7C MECHANICS

TYRE & WHEEL :

TYPE : Tube, Bias
TYPE SPEC. : 23.5 -25-16PR
RIM SPEC. : 15.0 X 25
DISC OFFSET : 4 mm

TRAVELLING PERFORMANCE :

MAX. SPEED : 38.0 KPH
MAX. TRACTIVE EFFORT : 16 TON
GRADEABILITY : 30° (58%)

HYDRAULIC SYSTEM

MAIN PUMP :

TYPE : FIXED GEAR
DISPLACEMENT : 100 cc/rev
MAX. FLOW RATE : 215 l/min
TANK PRESSURIZING DEVICE : SEMI
PRESSURISED (AIR BREATHER)

STEERING & PILOT PUMP :

TYPE : TANDEM, FIXED GEAR
DISPLACEMENT(STEER/PILOT) : 80 / 10 cc/rev.
MAX. FLOW RATE(STEER/PILOT) : 145 / 19 l/min

CONTROL VALVE :

TYPE : PILOT CONTROL WITH FLOAT SPOOL
NO. OF SPOOLS : 2
SPOOL ARRANGEMENT : BUCKET - LOADER ARM
RELIEF VALVE PRESSURE : 170 kgf/cm²
OVERLOAD RELIEF VALVE PRESS. : 190 kgf/cm²

REMOTE CONTROL VALVE :

TYPE : PILOT OPERATED TWO LEVER
(MONO LEVER) WITH MAGNETIC COILS
(DETENT COILS- ARM RAISE/FLOAT,
BUCKET CROWD)
PRESSURE/STROKE CHARACTER :
35 BAR @ 14 mm STROKE

SEQUENCE VALVE :

RELIEF PRESSURE : 35 bar

AIR BREATHER :

CRACKING PRESSURE : -0.05/0.35 (kgf/cm²)

ACCUMULATOR ; BRAKE :

CHARGE PRESSURE : 7.84 kgf/cm²
VOLUME : 34 L

STEERING SYSTEM

PUMP :

TYPE : GEAR
DISPLACEMENT : 80 cc/rev
CONSTANT FLOW : 145 l/min

STEERING UNIT :

TYPE : Coaxial Flow Amplifying
DISPLACEMENT : 1000 cc/rev.

PRIORITY VALVE :

LS CONTROL PRESSURE : 11 kgf/cm²
RATED PRESSURE : 140 kgf/cm²
CONVERGENCE DEVICES RELIEF PRESSURE :
140 kgf/cm²
MAX. OIL FLOW TO STEERING : 160 L/min

MAINTENANCE

Compartment /Grease Joint	No, Of C/G	Refill Capacity	Fluid or Lubricant	Service Interval (hr)	
				Lube	Filter
Cooling System	1	40 l	WATER	2000	-
Fuel Tank	1	300 l	DIESEL	-	500 (1st)
HYD. System	1	177 l	ISO #46	2000	1000
Engine Crankcase	1	19 l	SAE 15W40	500 (1st)	500 (1st)
Differential	Front	17 l	GEAR OIL	1000 (1st)	-
	Rear	17 l	GEAR OIL	1000 (1st)	-
Hub Reduction	Front	2 x 5 l	GEAR OIL	1000 (1st)	-
	Rear	2 x 5 l	GEAR OIL	1000 (1st)	-

Technical specifications **SD200**

Dimensions

ENGINE

MAKER & MODEL : Wei chai-Deutz WP6G125E22
(TIER-II Certified)
RATED HORSE POWER: 92 kW/2200rpm
MAX. TORQUE: 500 N.m (1400-1500rpm)
FUEL CONSUMPTION: 215g/kW.h @ RATED SPEED
TYPE : TURBO, DIRECT INJECTION

DISPLACEMENT : 6754cc
NO. OF CYLINDER : 6
BORE & STROKE : 105 X 130 (mm)
HIGH IDLE SPEED : 2376~2464 rpm
LOW IDLE SPEED : 750 rpm
STARTING MOTOR : 24V X 6kw

ALTERNATOR :

VOLTAGE : 28V
RATING AMPERES : 55A

FAN :

TYPE : BLOWING, 6 BLADE, STEEL
SIZE : Ø660 mm
RPM @ MAX ENGINE RPM : 2200rpm

BATTERY :

SYSTEM VOLTAGE : 24V
QUANTITY : 12V X 2
CAPACITY : 100 AH

RADIATOR :

TYPE (HEAT REJECTION AREA) : FLAT PLATE
FIN, AIR COOL (=44 m²)
HEAT REJECTION CAPACITY : 150,000 kcal/hr

AIR CLEANER :

TYPE : DRY, DOUBLE ELEMENT
FILTRATION AREA :
SIZE (DIA. X LENGTH) :

TRANSMISSION OIL COOLER :

TYPE (HEAT REJECTION AREA) : FLAT PLATE
FIN, AIR COOL (=17.8 m²)
HEAT REJECTION CAPACITY : 58,000 kcal/hr

MUFFLER :

DESCRIPTION : SIDE INLET, VERTICAL TAIL PIPE
SIZE : Ø200 mm X 440 mm

HYDRAULIC OIL COOLER :

TYPE (HEAT REJECTION AREA) : PLATE,
AIR COOL (=12.4 m²)
HEAT REJECTION CAPACITY : 40,400 kcal/hr

TRANSMISSION

TYPE: 4 FORWARD & 2 BACKWARD POWER-SHIFT,
SHAFT-FIXED, ENGINE REMOTE
MOUNTED WITH PROPELLER SHAFT & DAMPER
TORQUE CONVERTER STALL RATIO: 3.15
TORQUE CONVERTER SIZE: 315 mm
CHARGING PUMP FLOW: 64 L/min @2200rpm
HYDRAULIC PUMP P.T.O RATIO: 0.9387

POWER SHIFT CONTROL PRESSURE: 12 ~ 14 kgf/cm²
CONVERTER SAFETY RELIEF PRESSURE: 11 kgf/c m²
MAX. ROTATING SPEED: 2500rpm
SHIFT CONTROL: MECHANICAL TYPE
OUTPUT FLANGE: FRONT-9C MECHANICS
REAR-9C MECHANICS

AXLES

FRONT AXLE :

TYPE : FULLY FLOATING PLANETARY-TYPE HUB DRIVE
FIXED MOUNTING
OVERALL REDUCTION RATIO : 20.26
AXLE LOAD (EMPTY CONDITION) : 7,200 kg
AXLE LOAD (BREAKOUT CONDITION) : 18,500 kg
WHEEL BOLT P.C.D : Ø404mm
BRAKE TYPE : DRY DISC
BRAKE TORQUE per WHEEL : 9660 N.m at 98 bar
DRIVE FLANGE : 9C

REAR AXLE :

TYPE : FULLY FLOATING PLANETARY-TYPE HUB DRIVE
FIXED MOUNTING
OVERALL REDUCTION RATIO : 20.26
AXLE LOAD (EMPTY CONDITION) : 7,200 kg
AXLE LOAD (BREAKOUT CONDITION) : 18,500 kg
WHEEL BOLT P.C.D : Ø404mm
BRAKE TYPE : DRY DISC
BRAKE TORQUE per WHEEL : 9660 N.m at 98 bar
DRIVE FLANGE : 9C

TYRE & WHEEL :

TYPE : Tube, Bias
TYPE SPEC. : 17.5-25-12PR
RIM SPEC. : 14.0/1.5-25

TRAVELLING PERFORMANCE :

MAX. SPEED : 40.0 KPH
MAX. TRACTIVE EFFORT : 10 TON
GRADEABILITY : 30° (58%)

SD300 / SD200 Dimension and Working Ranges

SD300 / SD200

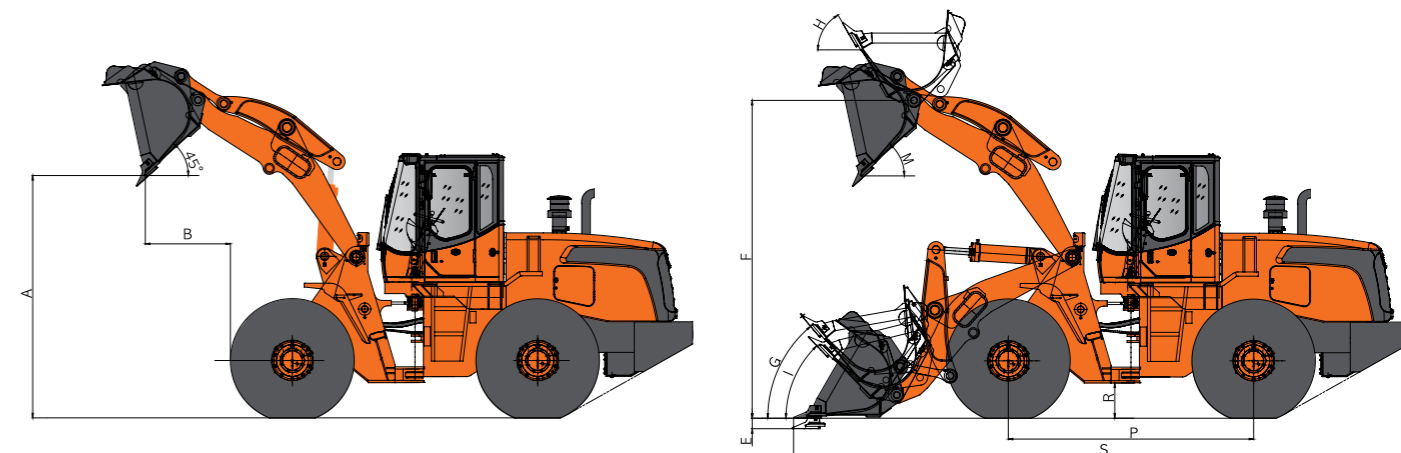

SD300 / SD200

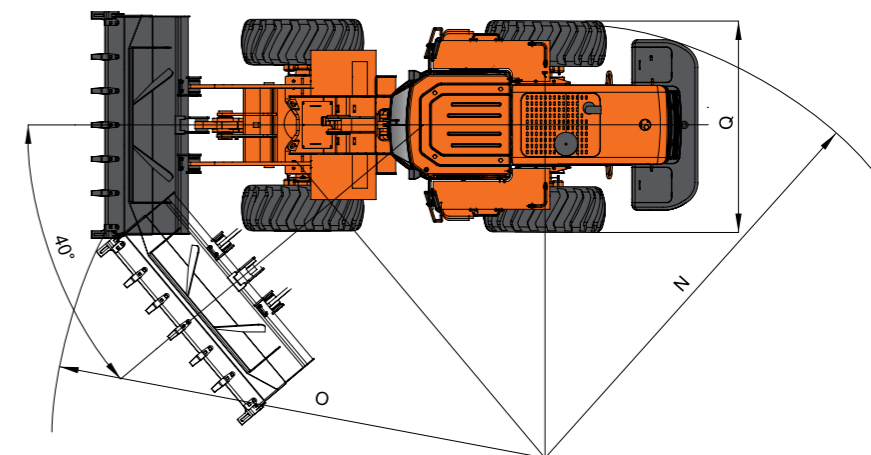

SD 300 / SD 200

Bucket type Configuration	Code	Unit	SD300				SD200			
			General purpose Teeth(Std.)	Teeth	Light material Base Edge	Rock Teeth	High Lift Teeth	General purpose Teeth(Std.)	Light material Base Edge	High Lift Teeth
Capacity heaped ISO/SAE		m ³	2.7	3.0	4.0	2.7	2.7	1.7	2.2	1.7
		yd ³	3.5	3.9	5.2	3.5	3.5	2.2	2.9	2.2
Bucket width		mm	2,992	2,992	3,092	2,960	2,992	2,506	2,506	2,506
		ft in	9'9"	9'9"	10'1"	9'8"	9'9"	8'2"	8'2"	8'2"
Breakout force		kN	161	161	132	161	150	96	92	94
		lbf	36,194	36,194	29,675	36,194	33,721	21,582	20,682	21,132
Static tipping load (straight)		kg	11,800	11,800	11,730	11,670	9,670	8,000	7,580	7,850
		lb	26,015	26,015	25,860	25,728	21,319	17,637	16,711	17,306
Static tipping load (at 40°)		kg	10,400	10,400	10,330	10,280	8,520	6,400	6,064	6,280
		lb	22,928	22,928	22,774	22,663	18,783	14,110	13,369	13,845
Dump height (at 45°) ¹⁾ (at fully raised)	A	mm	3,127	3,127	3,092	3,097	3,320	2,800	2,780	3,110
		ft in	10'3"	10'3"	10'1"	10'2"	10'10"	9'2"	9'1"	10'2"
Dump reach (at 45°) ¹⁾ (at fully raised)	B	mm	1,215	1,215	1,237	1,235	1,340	1,170	1,200	1,065
		ft in	3'11"	3'11"	4'	4'	4'4"	3'10"	3'11"	3'6"
Digging depth	E	mm	105	105	105	105	155	50	50	75
		ft in	4"	4"	4"	4"	6"	2"	2"	3"
Height at bucket pivot point	F	mm	4,150	4,150	4,150	4,150	4,410	3,740	3,740	4,030
		ft in	13'7"	13'7"	13'7"	13'7"	14'5"	12'3"	12'3"	13'2"
Max. tilt angle at carry position	G	•	50	50	50	50	51	50	50	50
Max. tilt angle at fully raised	H	•	60	60	60	60	60	60	60	60
Max. tilt angle at ground	I	•	45	45	45	45	45	45	45	45
Max. dump angle at fully raised	M	•	48	48	48	48	49	45	45	45
External radius at tire side	N	mm	5,900	5,900	5,900	5,900	5,900	5,250	5,250	5,250
		ft in	19'4"	19'4"	19'4"	19'4"	19'4"	17'2"	17'2"	17'2"
External radius at bucket edge	O	mm	6,510	6,510	6,560	6,550	6,790	5,710	5,750	5,870
		ft in	21'4"	21'4"	21'6"	21'5"	22'3"	18'8"	18'10"	19'3"
Wheel basis	P	mm	3,200	3,200	3,200	3,200	3,200	2,850	2,850	2,850
		ft in	10'6"	10'6"	10'6"	10'6"	10'6"	9'4"	9'4"	9'4"
Width at tyres	Q	mm	2,976	2,976	2,976	2,976	2,976	2,290	2,290	2,290
		ft in	9'9"	9'9"	9'9"	9'9"	9'9"	7'6"	7'6"	7'6"
Tread		mm	2,240	2,240	2,240	2,240	2,240	1,840	1,840	1,840
		ft in	7'4"	7'4"	7'4"	7'4"	7'4"	6'	6'	6'
Ground clearance	R	mm	450	450	450	450	450	340	340	340
		ft in	1'5"	1'5"	1'5"	1'5"	1'5"	1'1"	1'1"	1'1"
Overall length	S	mm	8,080	8,080	8,130	8,120	8,360	6,900	6,940	7,060
		ft in	26'6"	26'6"	26'8"	26'7"	27'5"	22'7"	22'9"	23'2"
Overall height		mm	3,470	3,470	3,470	3,470	3,470	3,280	3,280	3,280
		ft in	11'4"	11'4"	11'4"	11'4"	11'4"	10'9"	10'9"	10'9"
Operating weight		kg	16,800	16,850	17,020	17,130	17,100	10,400	10,460	10,420
		lb	37,038	37,148	37,523	37,765	37,699	22,928	23,060	22,972

1) Measured to the tip of the bucket teeth or bolt-on edge.
2) All measurements with tyres 23.5-25-16PR(L3).

1) Measured to the tip of the bucket teeth or bolt-on edge.
2) All measurements with tyres 17.5-25-12PR.

SD 200

HYDRAULIC SYSTEM

MAIN PUMP :

TYPE : FIXED GEAR
DISPLACEMENT : 100cc/rev
MAX. FLOW RATE : 192l/min
TANK PRESSURIZING DEVICE : AIR BREATHER

STEERING & PILOT PUMP :

TYPE : FIXED GEAR
DISPLACEMENT(STEER/PILOT) : 100/100cc/rev.
(STEER, SHARING with MAIN PUMP)
MAX. FLOW RATE(STEER/PILOT) : 192/19L/min
(STEER, SHARING with MAIN PUMP)

CONTROL VALVE :

TYPE : PILOT CONTROL WITH FLOAT SPOOL
NO. OF SPOOLS : 2
SPOOL ARRANGEMENT : BUCKET - LOADER ARM
RELIEF VALVE PRESSURE : 170 kgf/cm²
OVERLOAD RELIEF VALVE PRESS. : 190 kgf/cm²

REMOTE CONTROL VALVE :

TYPE: PILOT OPERATED TWO(MONO)
LEVER WITH MAGNETIC COILS
(DETENT COILS-ARM RAISE/FLOAT,
BUCKET CROWD)
PRESSURE : 35 bar

SEQUENCE VALVE :

RELIEF PRESSURE : 35 bar

ACCUMULATOR ; BRAKE :

CHARGE PRESSURE : 7.84 kgf/cm²
VOLUME : 34L

STEERING SYSTEM

PUMP :

TYPE : GEAR
DISPLACEMENT : 100 cc/rev
(SHARING with MAIN PUMP)
CONSTANT FLOW : 192 l/min
(SHARING with MAIN PUMP)

STEERING UNIT :

TYPE : Coaxial Flow Amplifying
DISPLACEMENT : 630cc/rev.

PRIORITY VALVE :

LS CONTROL PRESSURE : 11 kgf/cm²
RATED PRESSURE : 140 kgf/cm²
MAX. OIL FLOW TO STEERING : 160 L/min

MAINTENANCE

Compartment / Grease Joint	No. Of C/G	Refill Capacity	Fluid or Lubricant	Service Interval (hr)	
				Lube	Filter
Cooling System	1	24 ℓ	WATER	2000	-
Fuel Tank	1	150 ℓ	DIESEL	-	500 (1st)
HYD. System	1	126 ℓ	ISO #46	2000	1000
Engine Crankcase	1	14 ℓ	SAE 15W40	500 (1st)	500 (1st)
Differential	Front	9 ℓ	GEAR OIL	1000 (1st)	-
	Rear	9 ℓ	GEAR OIL	1000 (1st)	-
Hub Reduction	Front	2 x 4.5 ℓ	GEAR OIL	1000 (1st)	-
	Rear	2 x 4.5 ℓ	GEAR OIL	1000 (1st)	-

Operational Data

Option Plan

	Classification	SD300	SD200	Remarks
BUCKET	1.7 m ³ - General purpose	X	■	
	2.2 m ³ - Light material	X	●	
	2.7 m ³ - General purpose	●	X	
	3.0 m ³ - General purpose	■	X	
	2.9 m ³ - Cutting edge	●	X	
	3.2 m ³ - Cutting edge	●	X	
	2.7 m ³ - Rock version	●	X	
	4.0 m ³ - Light material	●	X	
WORK LEVER	Mono lever	■	■	
	Two lever	●	●	
Tire (Tube Type)	Xulun	X	■	17.5-25-12PR
	Xulun	■	X	23.5-25-16PR
	Feng shen	●	X	For desert, 23.5-35-16PR
	Triangle	●	X	23.5-25-16PR
Tire (Tubeless Type)	Xulun	●	X	23.5-25-16PR
	Triangle	●	X	23.5-25-16PR
	Triangle, Radial	●	X	23.5R25
FRONT	Standard	■	■	
	High Lift (Long boom)	●	●	Equipped with 2.7m ³ bucket on a 5 ton long boom 3.0m ³ /4.0m ³ bucket available only for the coal digging bucket (For SD300)
T/M	LZ ZF -F4 - R3	X	X	
	DISD - F2 / R1	X	X	
	Hangchi	■	X	
	Jingyi	X	■	
COOLING	STD	■	■	
	Tropical specification	X	X	
CABIN	General grass	■	■	
	Tinted glass	●	●	

* STANDARD : ■ / OPTION : ● / None : X

DISD

No. 1088, Xincheng Street. Muping Economic Developing Zone
Yantai Shandong 264100 China

Tel : +86-535-638-2000 Fax : +86-535-638-2004

